

reis

JOINING AND CUTTING TECHNOLOGIES

WELDING, CUTTING, COATING, LASER PROCESSING, JOINING,
BONDING



CUSTOMIZED SYSTEM SYSTEMS

Our customized & application-specific **robot systems**, developed, built and programmed in-house, offer customized solutions for the individual needs of our customers.

Based on standardized modules and our innovative **ROBOTstar VII** high-performance controller, we develop robot systems ranging from compact cells to fully automated production lines.

In close cooperation with our application partners and by using the latest technologies, we generate an efficient, scalable and innovative solution that increases productivity and reduces operating costs.



WELDING PROCESSES

Welding processes are central technologies in metal processing in which materials are joined inseparably using heat and/or pressure. Different techniques are used depending on the application, material and requirements. Modern monitoring systems ensure precise quality control to guarantee maximum process reliability. Integrated, adaptive sensor technology optimizes seam detection, seam tracking and gap detection.

MIG & MAG WELDING

Many years of experience in the thin and thick sheet metal sector and process-specific qualification of welding technology, e.g.:

- Single wire, cored wire, hot wire
- Double wire
- CMT
- High-performance welding processes
- Laser hybrid



PTA WELDING

High-quality coating systems for maximum efficiency.

- Plasma cladding can be used to effectively protect wear components
- Partial component machining offers reliable wear protection for various components
- Depending on the requirements, both welding wires and powder can be processed

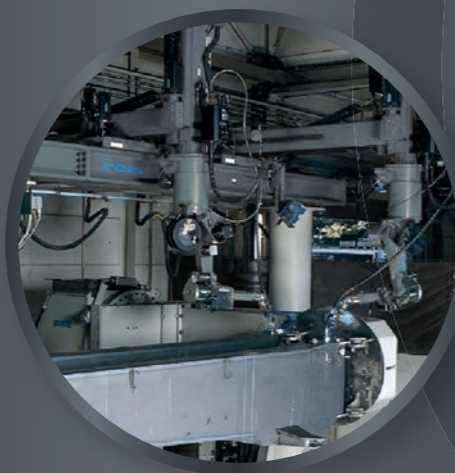
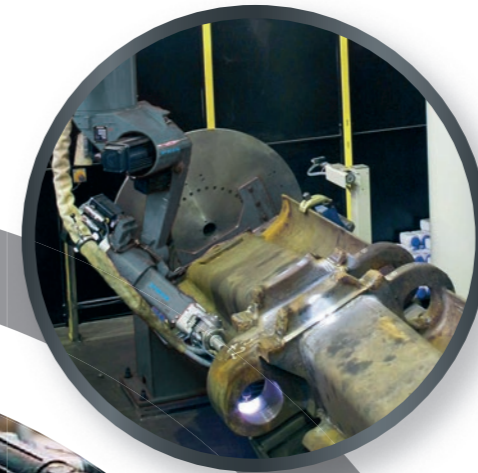

TIG & PLASMA WELDING

Precision welding processes, e.g. TIG high-performance welding with a focused arc – also with cold wire feed depending on the task – are available in conjunction with high-precision robot and peripheral modules for demanding tasks in robotics.

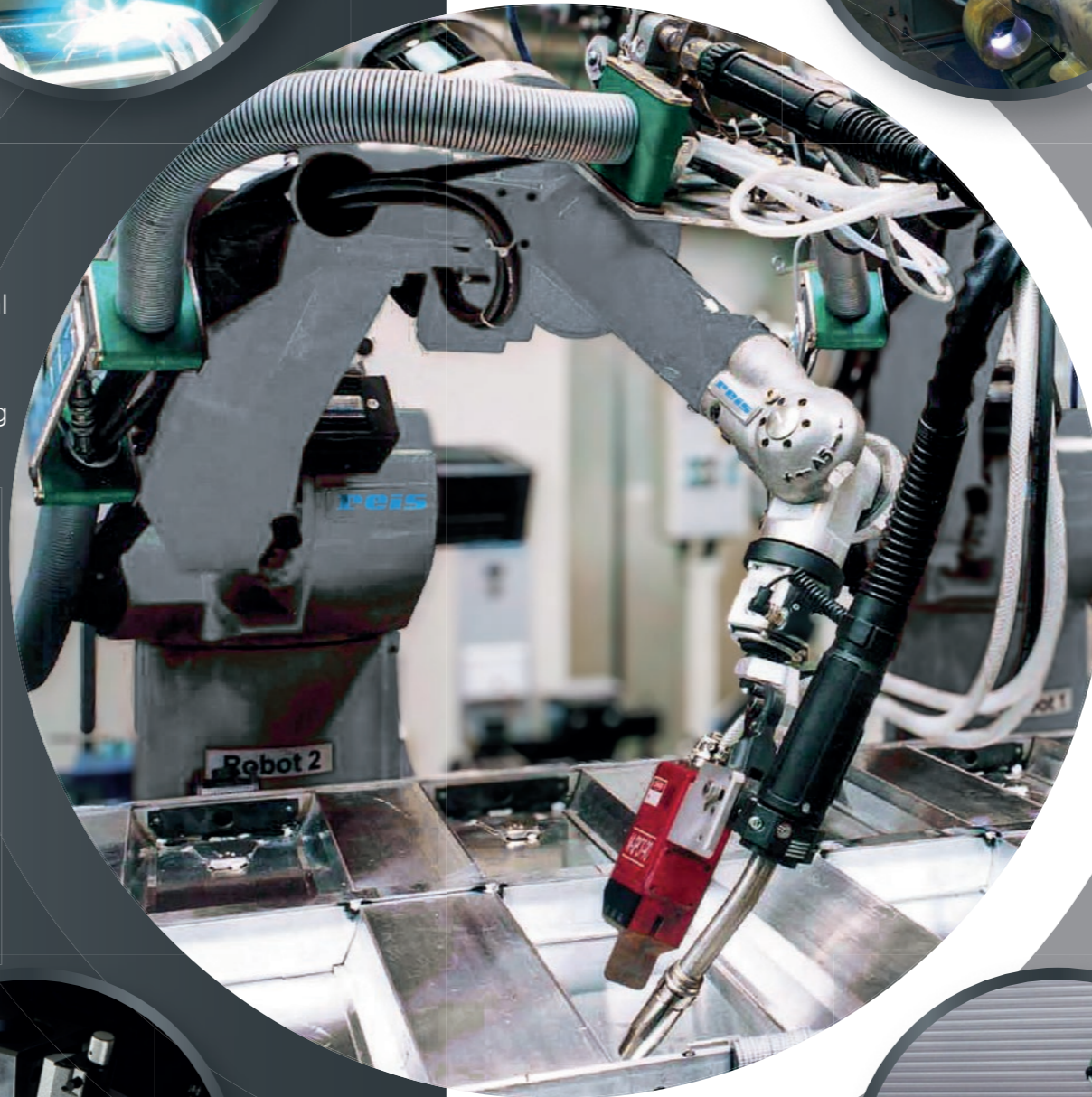
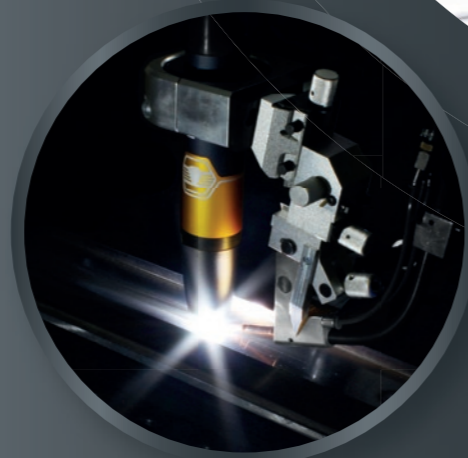

RESISTANCE WELDING

A wide variety of robot kinematics for customized solutions. Component handling on stationary resistance welding machines for adapted material flow. Future technology for the shortest processing times.

- It is possible to use freely programmable servo welding guns from all manufacturers
- The monitoring, evaluation, regulation and recording of welding parameters is made possible

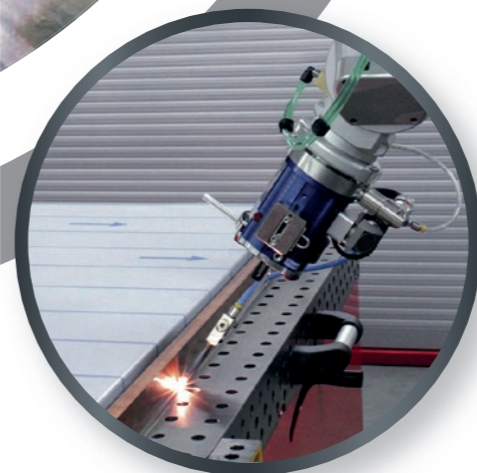

LASER WELDING

- Wobbling
- With cold wire
- Also available with tool change
- 2D-3D scanner
- Laser hybrid



WELDING

LASER, MIG, MAG, WIG, PLASMA, PTA and RP

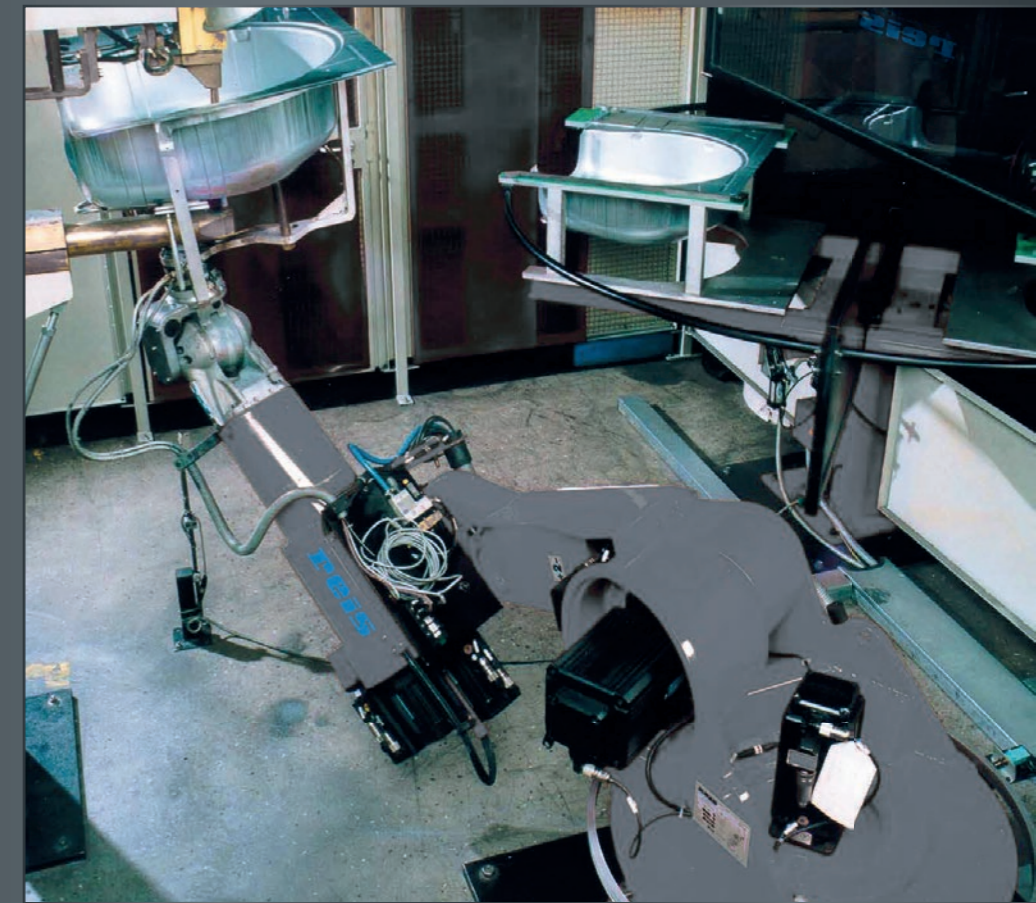

REIS ROBOTICS is at the forefront of modern automation technology and has not only established itself as a leading provider in the field of robot-supported process technologies, but has also set standards with many innovations and patents. In conjunction with the use of particularly powerful, dynamic and precise robots, we not only open up new potential for increasing efficiency, but also significantly improve the quality of the results.

The innovative **ROBOTstar VII** control software from **REIS ROBOTICS** is designed to support a wide range of welding processes, including **MIG** (metal inert gas), **MAG** (metal active gas), **TIG** (tungsten inert gas), **plasma**, **RP**, **PTA** (plasma transfer arc) and **laser welding**, as well as various **cutting and coating processes**.

ADVANTAGES

- We offer **customized solutions** that are tailored to the individual requirements of our customers
- Our comprehensive automation systems ensure **maximum productivity in production**
- Our cooperating robots are ideal for processing and handling materials
- We enable the **interlinking of different tasks** to realize complex system solutions
- Our flexible manufacturing islands and production lines are **scalable**

ADVANTAGES

- **ROBOTstar VII** – a highly flexible controller without license costs and special additional software packages
- The programming is standardized for all processes, ensuring consistent operation
- Up to 128 freely programmable axes are available, including 24 axes that can be managed and interpolated simultaneously by the control software
- The OPC/UA interface with connection to a host computer enables higher-level production control and monitoring, as well as centralized management of the systems and process parameters

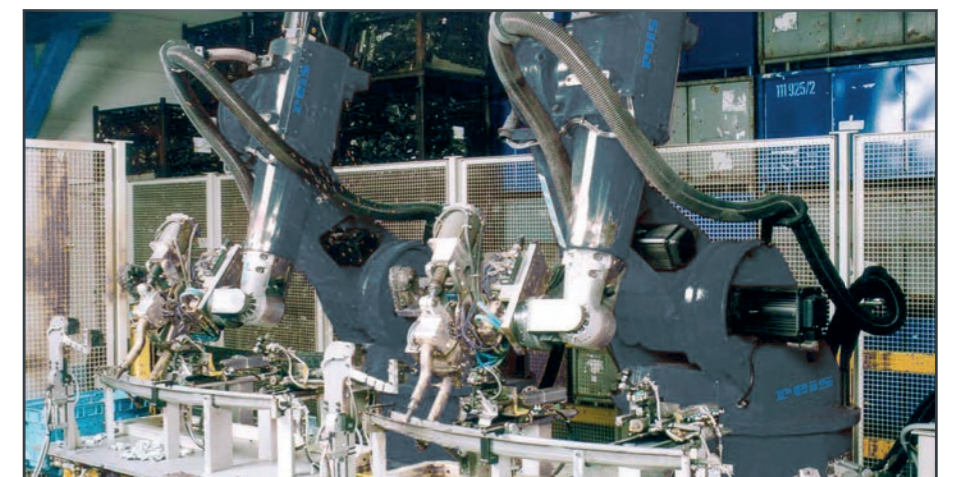

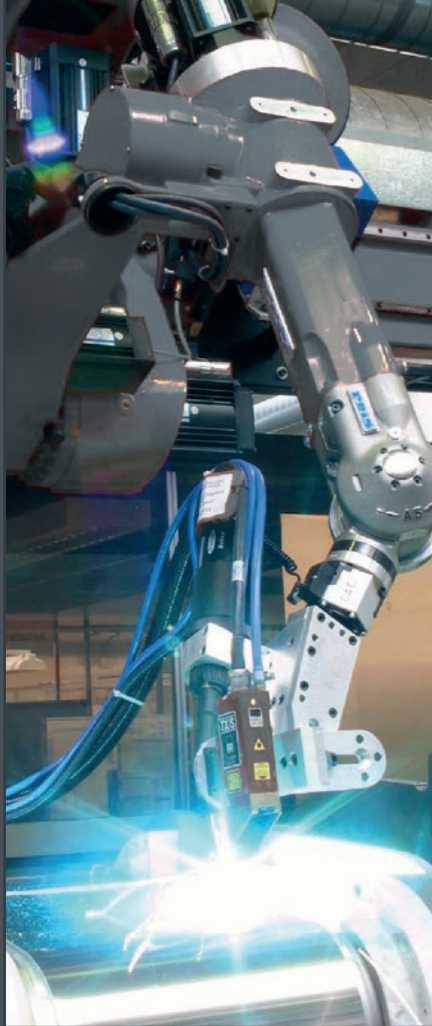

MIG (METAL INERT GAS WELDING)

Flexible and fast 3D processing. Many years of experience in stainless steel and aluminum.

- Enables welding with very high Temperature
- MIG welding is ideally suited to the manufacture of containers, truck tanks, scaffolding elements, etc.

MAG (METAL ACTIVE GAS WELDING)

MAG welding uses active gases such as CO₂ or mixtures of argon and CO₂.

- Integrated process and quality monitoring for process reliability
- Sensors (seam detection, seam tracking and gap detection) for the best quality
- Integrated multi-axis transformation for optimal component processing

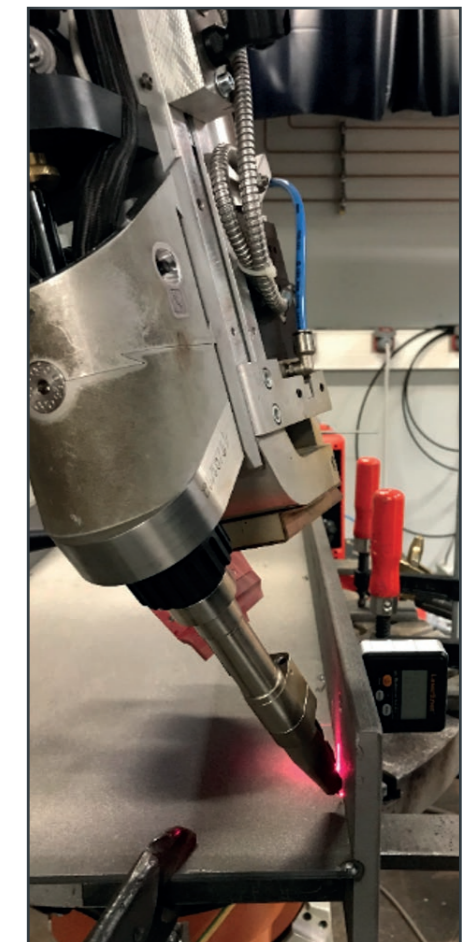
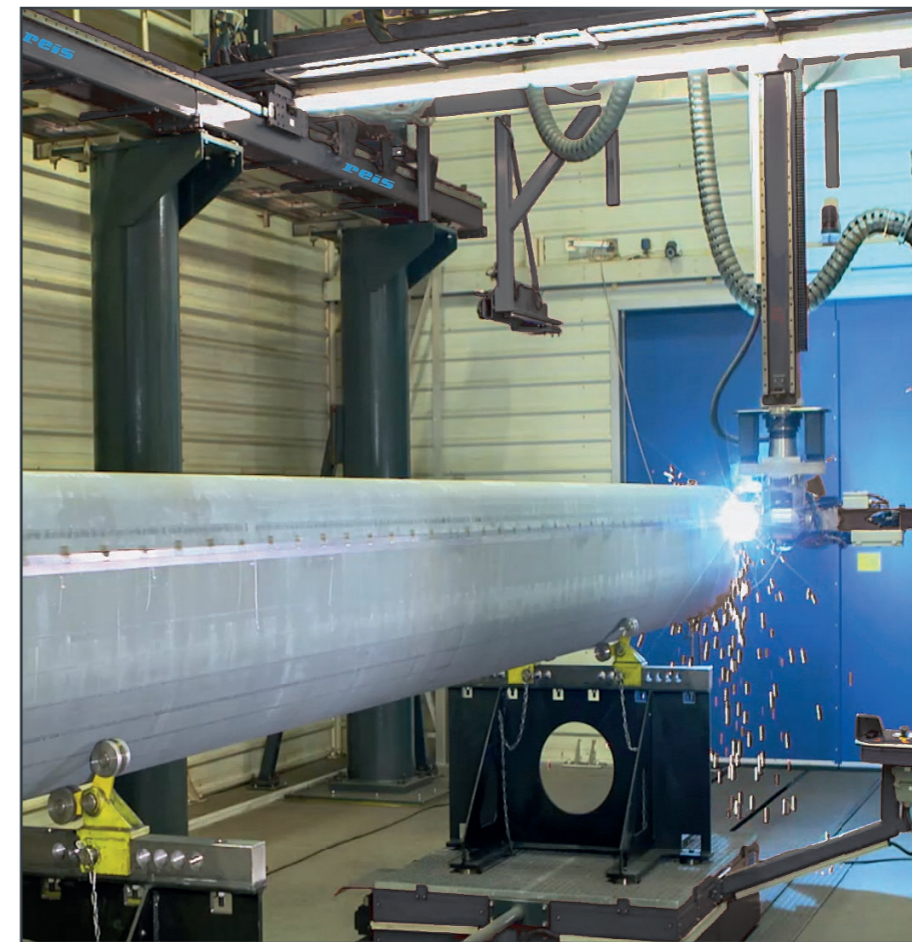

LASER HYBRID WELDING

This process is a combination of laser beam welding and the MSG process. As a rule, thick sheets are welded in order to possibly combine strength and notch effect under dynamic load through the full connection without backing and without large dimensions.

The LHW process achieves higher welding speeds, reduces the effort required for seam preparation, allows with the appropriate filler wire and reduces the distortion of the component. The working window is defined by the direct and decoupled process

depending on many factors. The MSG process can also be used to support the laser process with the appropriate filler material feed when thinner material thicknesses are required.

Comparison of firing ratio and firing depth (shown as a micrograph)

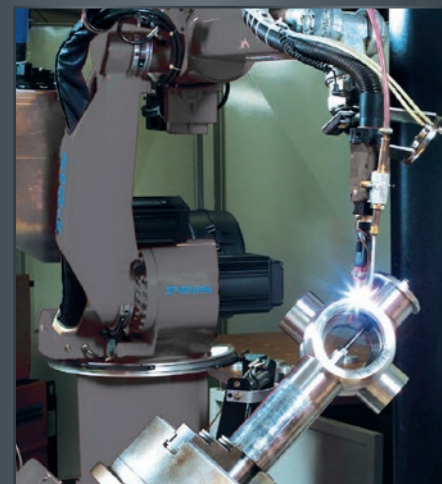

WIG (TUNGSTEN INERT GAS WELDING)

Particularly suitable for welding stainless steel, aluminum and other high-quality metals.

- High-precision robot and peripheral modules for demanding tasks
- Arc controllability allows for clean working
- Exact seams without slag inclusions and without reworking



FOCUSED TIG-WELDING

Benefit from outstanding quality, impressive efficiency and versatility for particularly demanding applications.

- High welding speed for increased productivity
- Excellent seam quality with minimal energy input
- Single-layer welding up to 10 mm for reduced pre- and post-work
- Versatile use for different materials and in a wide range of applications

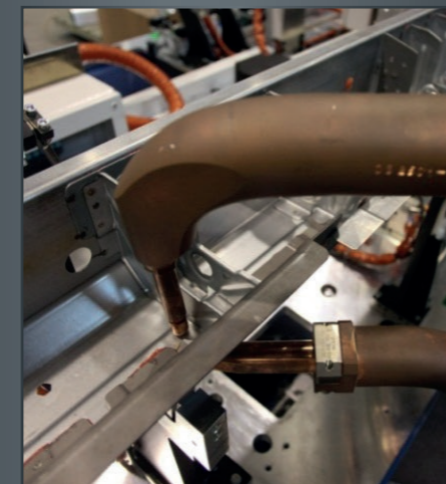

RESISTANCE SPOT-WELDING

The process is based on the selective heating and liquefaction of two workpieces pressed together by applying a strong voltage.

- Low component distortion due to welding heat
- High energy efficiency
- High cost-effectiveness
- No additional material required
- Suitable for a wide range of material combinations

STEEL 10 MM LASER

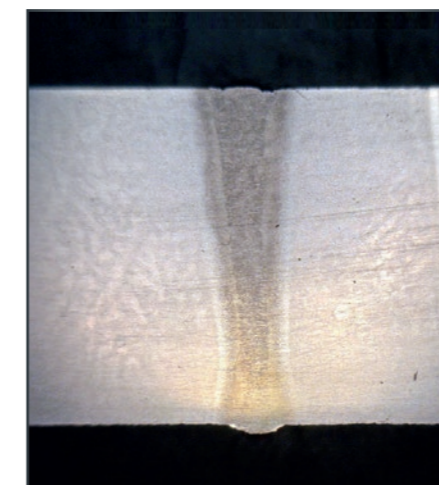

STEEL 10 MM MAG

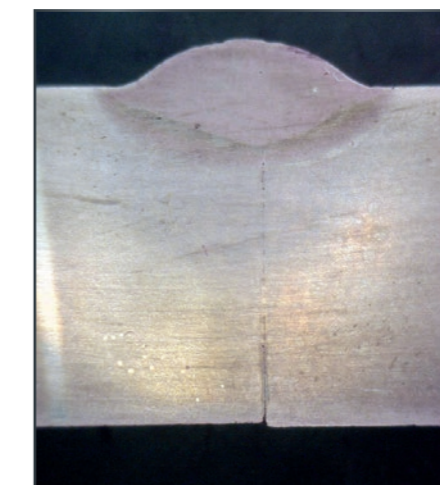

STEEL 10 MM LASER HYBRID



LASER-MATERIAL PROCESSING

Laser material processing has become a key technology that is qualified in modern industrial automation. It enables the precise, contactless processing of various materials and is used in numerous industries such as automotive, electronics, aerospace and medical technology. Laser technology allows materials to be cut, engraved, welded, hardened and marked – all with high precision and in the shortest possible time.

Lasers can be controlled precisely and quickly in automated production. By integrating laser technology into automated manufacturing systems, companies can shorten production times while increasing flexibility and product quality.

3D laser-generated component



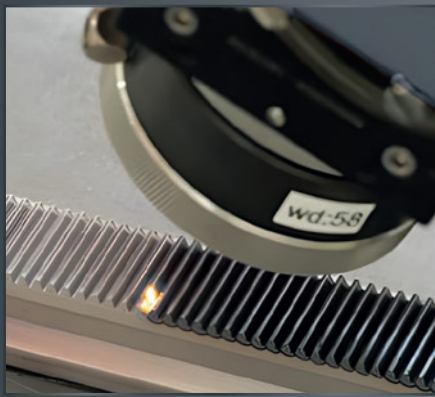

LASER HARDENING

- Highly flexible process
- Utilization of material-specific energy input
- Adjustable hardening depth
- Spot heating and cooling
- Flexible hardening membranes thanks to special optics
- Zoom spots enable width and contour-adapted hardening paths
- QA control parameters by power-regulating pyrometer
- Offline programming to effectively process 3D components

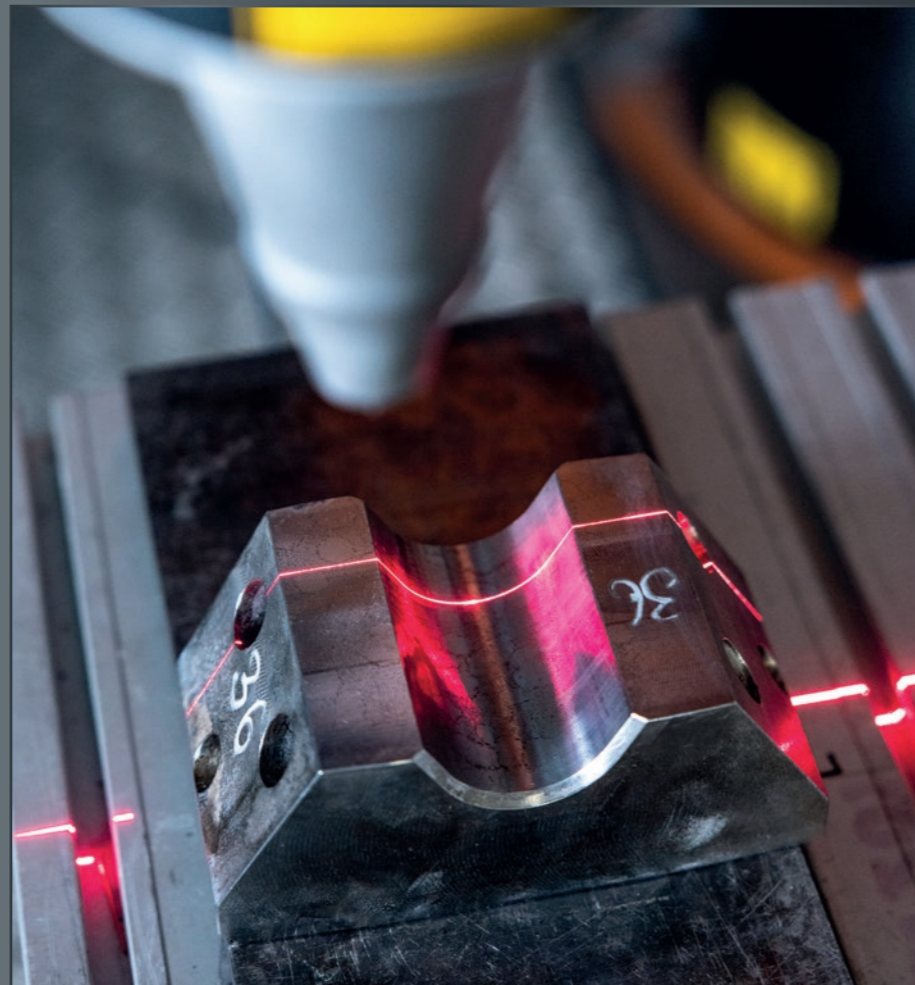

© MCR Engineering Lausitz, Photographer: Andreas Franke

LASER METAL DEPOSITION

- Additive manufacturing process for metals
- Repair welding
- Reusability of complex and expensive components
- Coatings as wear protection
- Creation of 3D geometries



LASER HARDENING

Laser hardening is a high-precision, efficient hardening process for producing a defined surface hardness of steel materials. In this process, the laser beam is moved to a defined and adjustable spot size on the workpiece. By using a pyrometer, the energy input can be controlled precisely and efficiently.

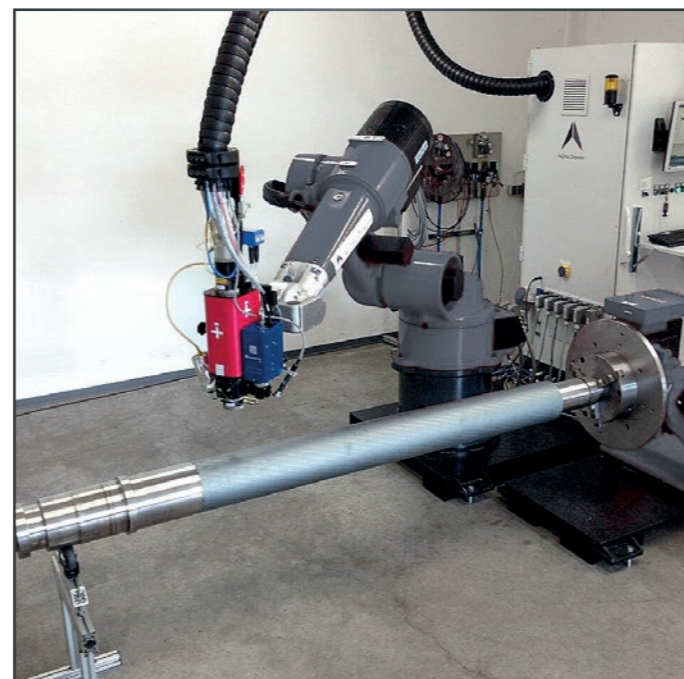
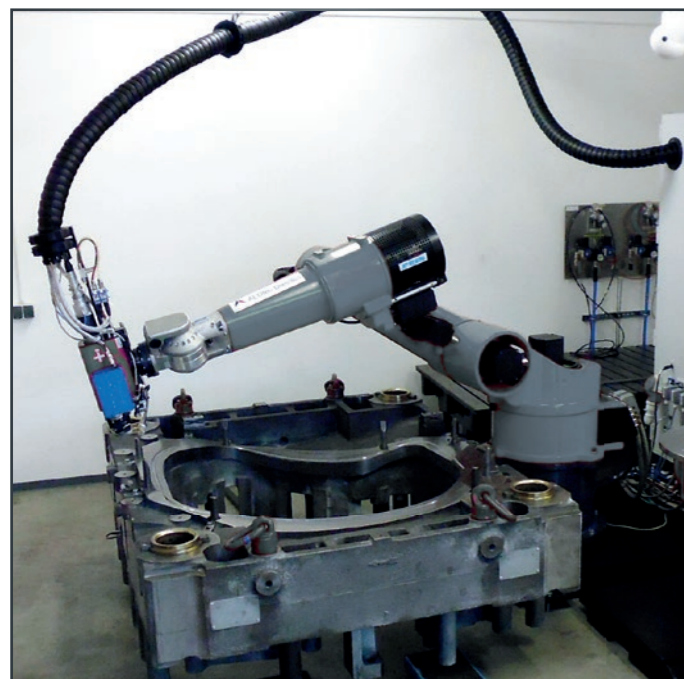

LASER CLADDING

Laser cladding is an innovative welding process in which a defined laser beam spot is used to apply a filler material (powder or wire) to the workpiece in different dimensions.

- High-quality, as well as visually appealing Welds
- Low heat input and thus lower melting depth
- Joining of a wide range of alloys possible
- Adjustable welding paths
- Defined and high deposition rate

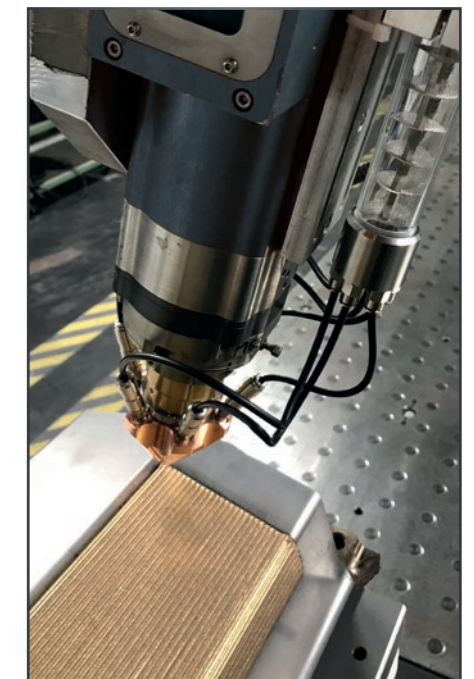

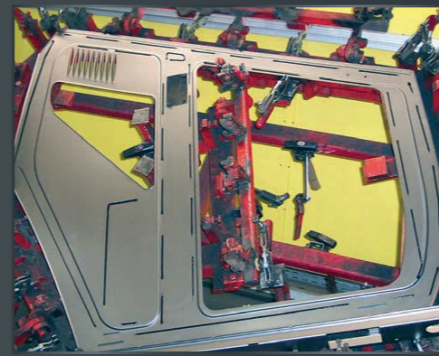
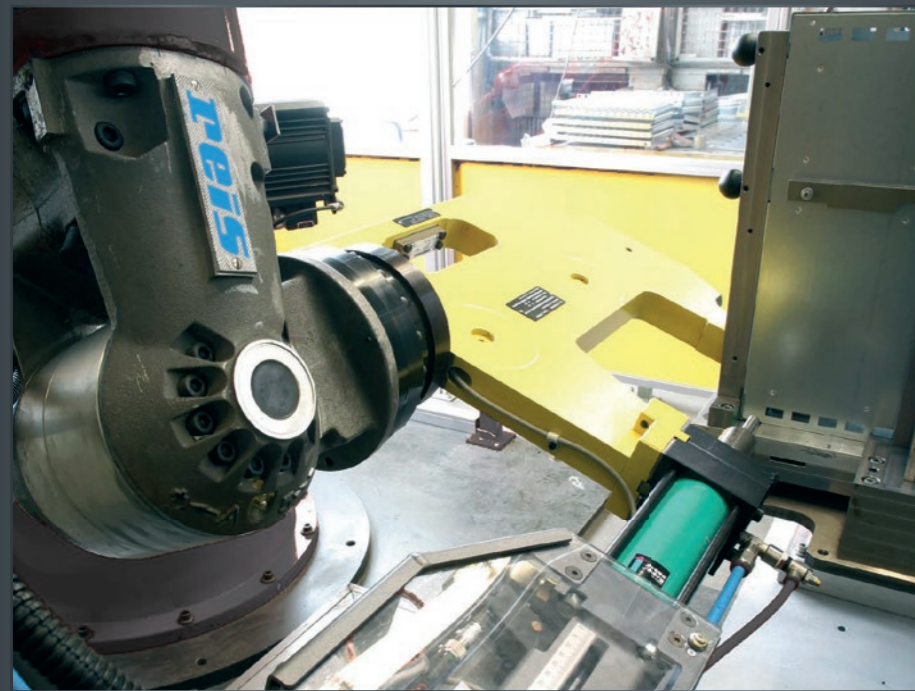

CLINCHING

Also known as clinching, this is a process in which material is joined by plastic deformation without additional parts.

- Form- and force-fit
- Low consumption costs
- Joining a wide variety of materials
- No requirements for the surface finish

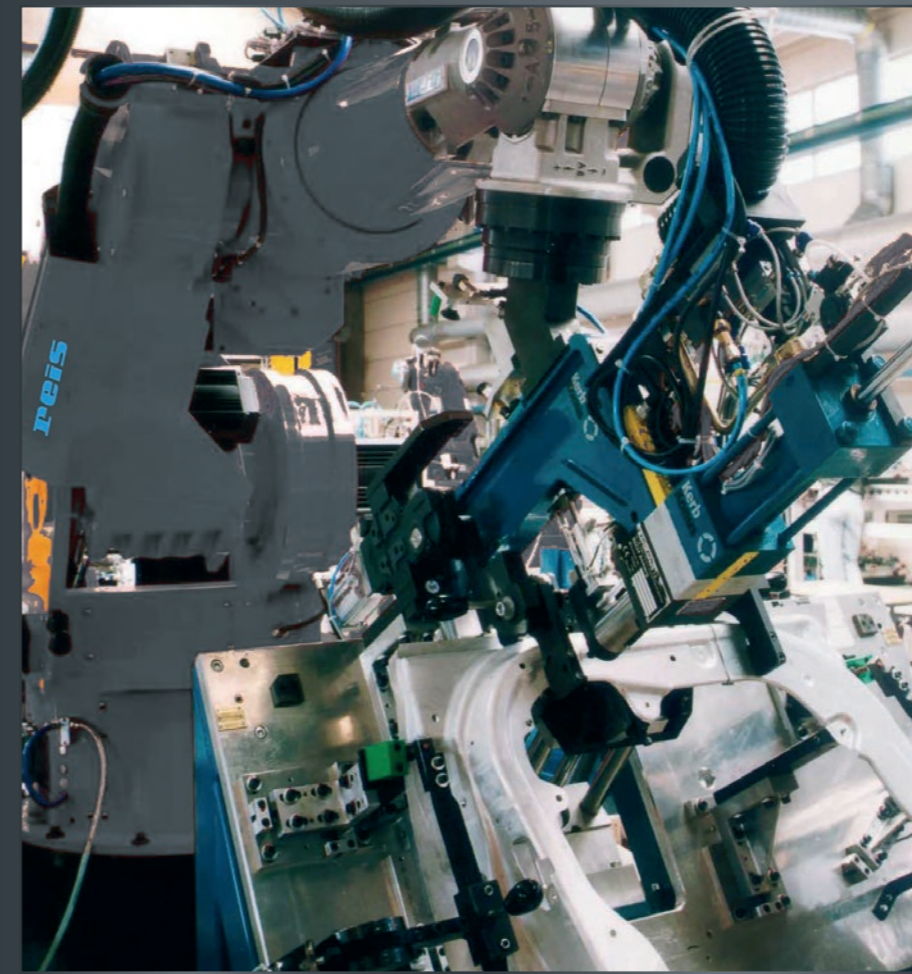

PUNCH RIVETING

A mechanical process in which a rivet element is pressed through the materials to be joined and deformed to create a strong joint. It is ideal for joining dissimilar or coated materials.

- High-strength, optically inspectable joint
- Distortion-free connection
- Reproducible joining result
- For dissimilar materials
- For different material thicknesses and material strengths
- Hybrid joints possible in combination with adhesive

ALTERNATIVE JOINING PROCESS

Alternative joining processes are innovative and proven methods of joining materials without traditional welding or bolting. These methods are used in particular when conventional joining techniques reach their limits or when special requirements such as material conservation, weight savings or the avoidance of thermal influences need to be met.

BONDING

A joining process in which adhesives are used to join materials together. Bonding enables an even distribution of tension and is particularly suitable for joints with different materials. It is a connection with high fatigue strength.

- Noise minimization
- Sealing/sealing of component edges
- Can be combined with other joining techniques
- Distortion-free connection

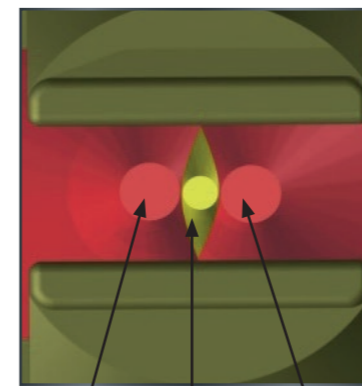
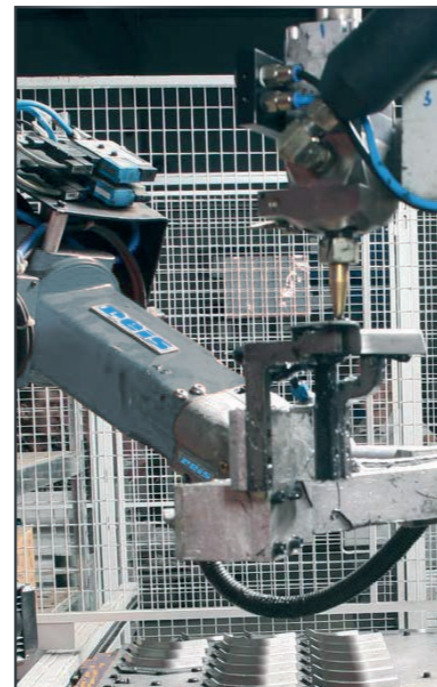
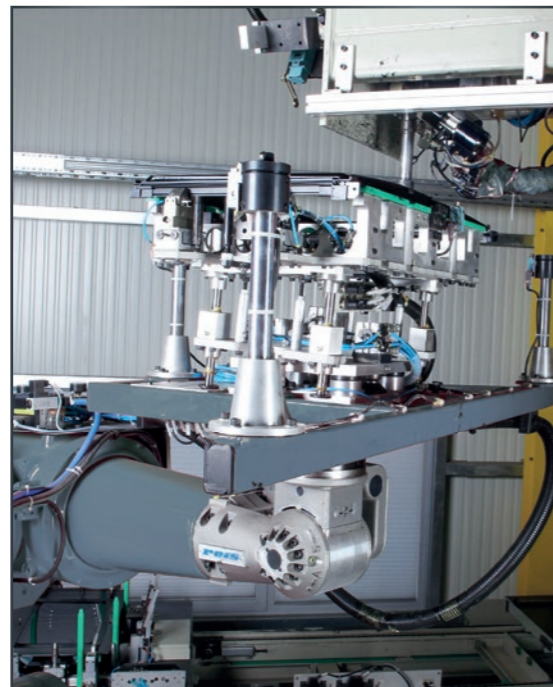

Pyrometer spot
Laser spots 250W each

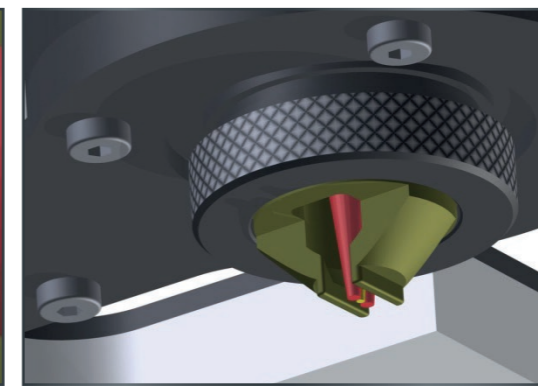

Specially adapted nozzle geometry for reduced contamination in 24/7 mass production

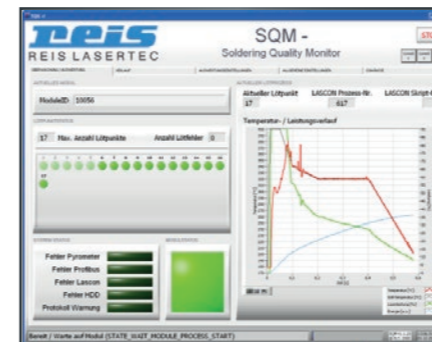

SOLDERING

A thermal process in which a solder material is melted to connect the joining partners by adhesion. It is particularly suitable for sensitive components and electronic connections, as it is carried out at comparatively low temperatures and does not melt the components.

- Separation of laser spot and measuring range
- Reduced influence of material surface and contamination
- Better positioning tolerances in the process
- Better solder distribution
- Lower Process Variation
- Integrated process control and quality monitoring

CUTTING PROCESS

The innovative technology of **REIS ROBOTICS** makes it possible to fully exploit the potential of automated material processing through the use of powerful and precise cutting robots. These robots are not only capable of performing highly complex cutting operations, but also offer exceptional flexibility and accuracy, which are essential in today's industrial manufacturing environment.

The ingenious concept and advanced technology of **REIS** robots enable the efficient use of various cutting processes.

ADVANTAGES

- Freely programmable torch adjustment with camera for online correction for the creation of top and/or bottom cuts (K-seam preparation)
- Freely selectable cutting table assignment
- Practical safety concepts
- Sheet thickness correction and kerf compensation for optimum quality
- Quick-change device for plasma and oxyfuel
- Complex contours as well as bevel transitions and constant web
- Offline programming system for batch size 1

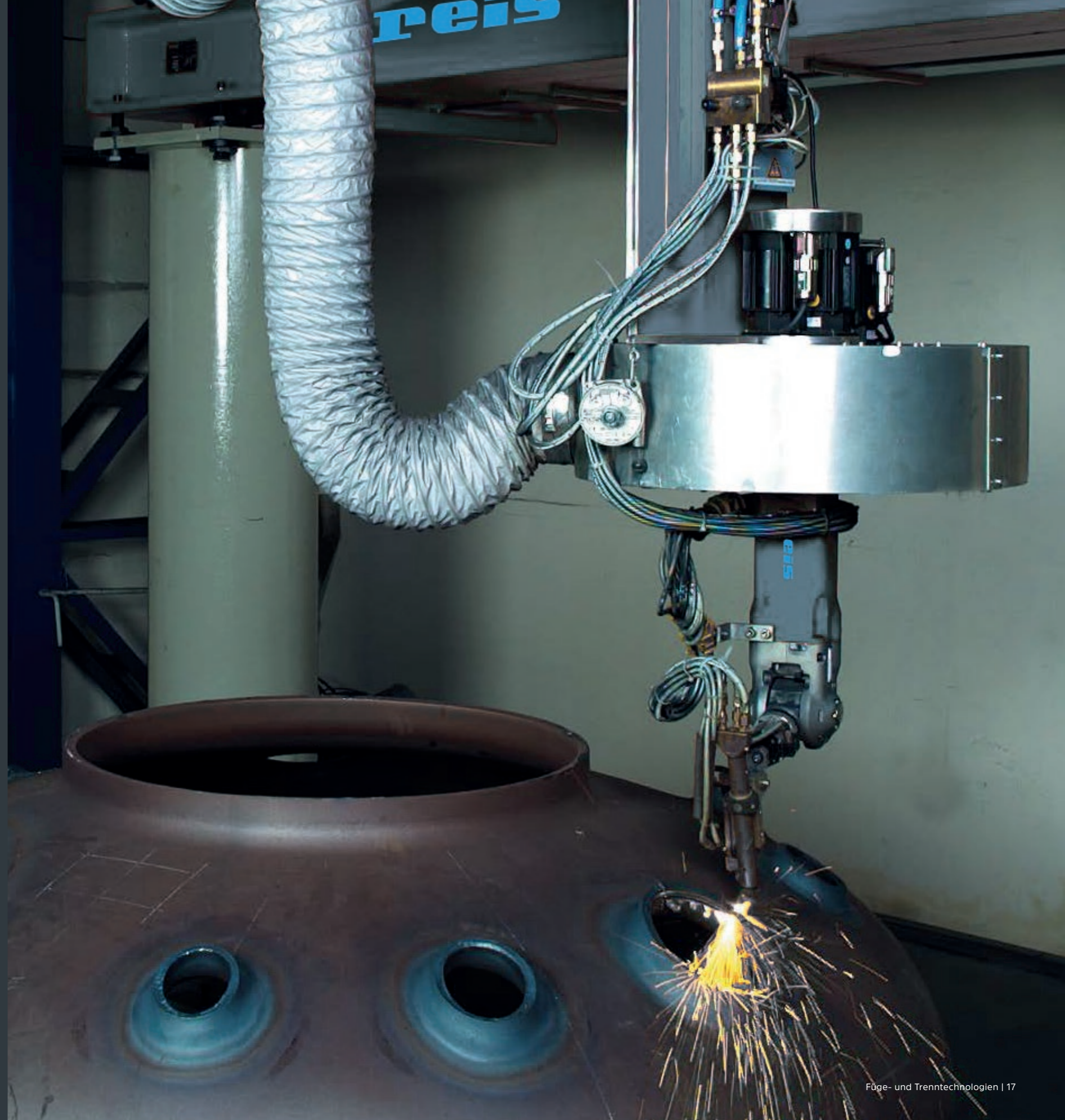

OXYFUEL, PLASMA, LASER CUTTING

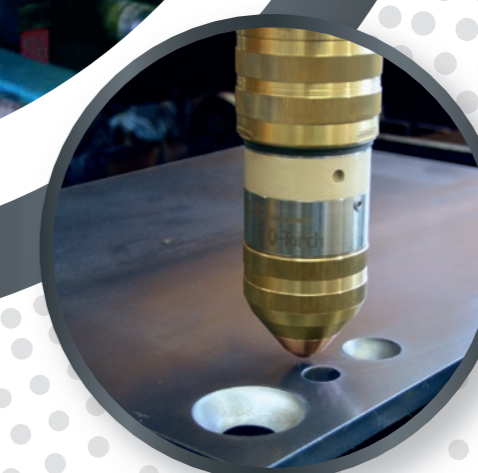
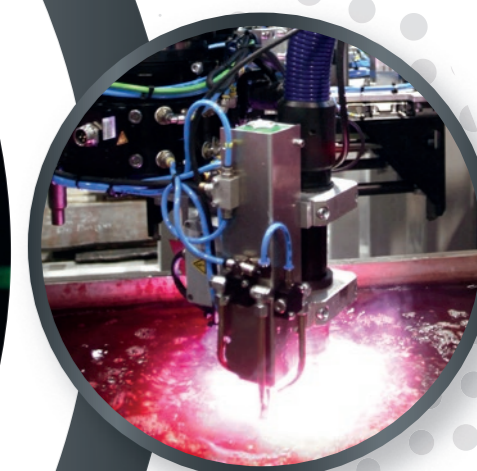
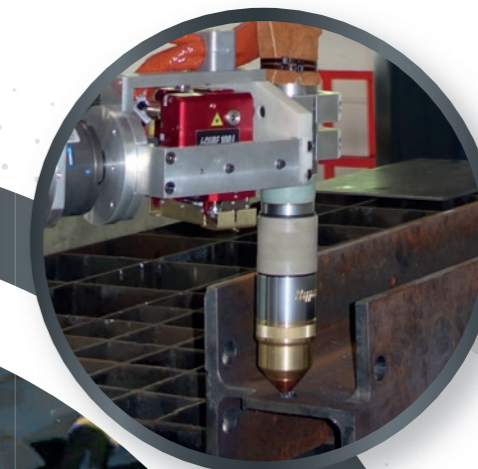

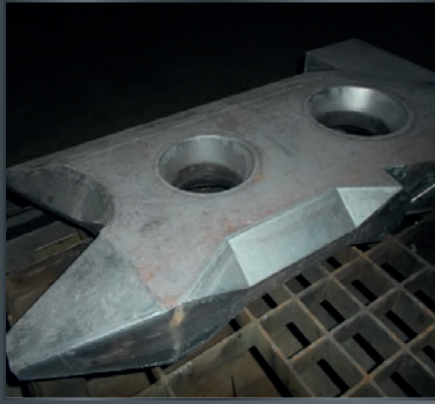

OXYFUEL CUTTING

Use of e.g. acetylene, propane and natural gas. Preheating function, e.g. for fine-grain structural steels.

- Technology Database
- Automatic ignition device
- Flame Monitoring
- Automatic Hole Punching

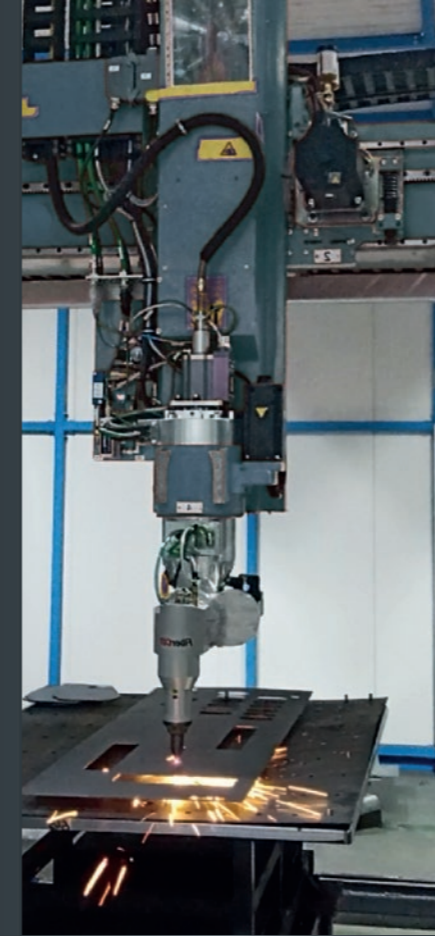

PORTAL FIBER LASER

- High cutting speeds
- Precise laser cuts
- High cutting quality
- Low energy consumption
- Low maintenance costs
- Flexible cutting optics
- Offline programming

OXYFUEL & PLASMA CUTTING

Oxy-fuel and **plasma cutting** are thermal cutting processes. In oxy-fuel cutting, the material is ignited and burned by a combination of preheating flame and oxygen jet to cut it – ideal for unalloyed and low-alloy steels. Plasma cutting, on the other hand, uses an electric arc to generate a high-energy plasma that drives the liquid material out of the kerf – suitable for all electrically conductive materials. Both processes offer precise cuts, but differ in their application and variety of materials.

PLASMA CUTTING

Cutting systems up to 450 A/600 A, quality cuts up to 100 mm.

- Technology Database
- Kerf compensation
- Distance regulation



3D LASER CUTTING

3D laser cutting is a very efficient, ultra-modern and continuously optimized cutting process. Depending on the beam generation and wavelength, it is possible to cut metals, wood or plastics. In combination with powerful offline programming systems, high-precision 3D cuts can be realized with a robot. In addition to the high precision and accuracy, further advantages result from the laser-compatible design and production for the subsequent processes. This significantly reduces component distortion, fixture and reworking costs during laser welding, for example.

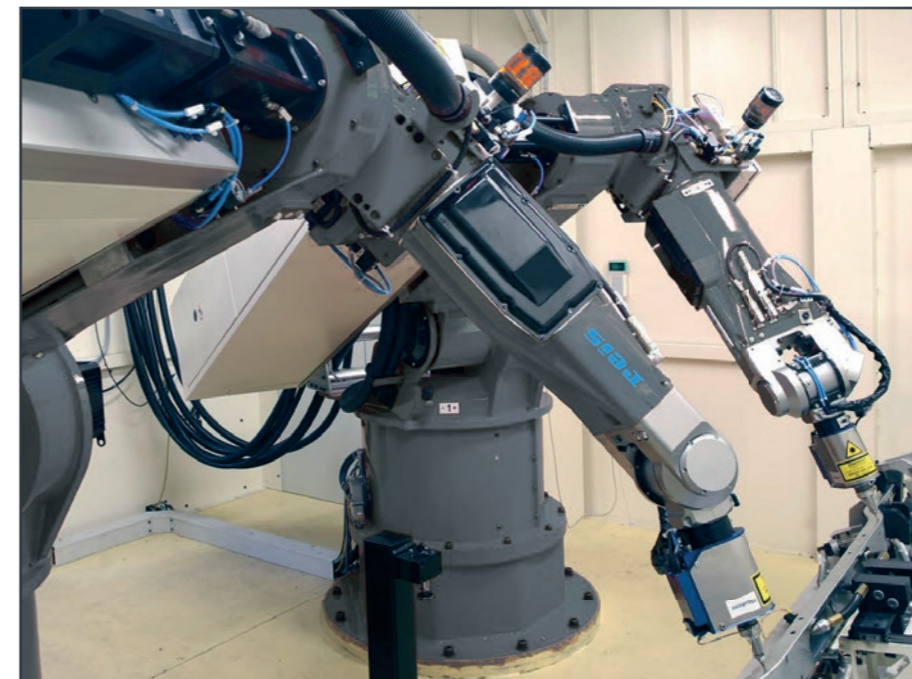

Flexible and fast 3D machining.

- High Cutting Speed
- No wear and tear on the tool
- Less programming effort
- No reaction forces on the component and on the device



POSITIONERS

A MODULAR SPECTRUM

We offer positioners for loads from 200 kg to 12,000 kg, which are equipped with external, freely programmable robot axes.

Our extensive range of positioners is specially adapted to our powerful **ROBOTstar VII** control software.

The additional axes of the positioners are freely programmable, interpolatable and fully fully integrated into the control software, ensuring maximum flexibility and precision in the application.

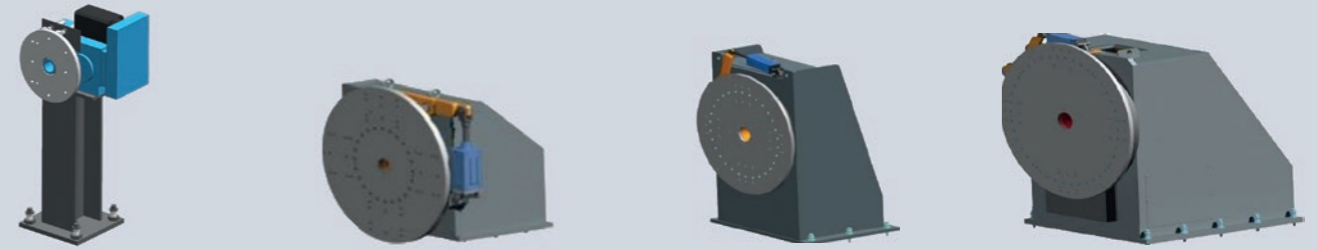
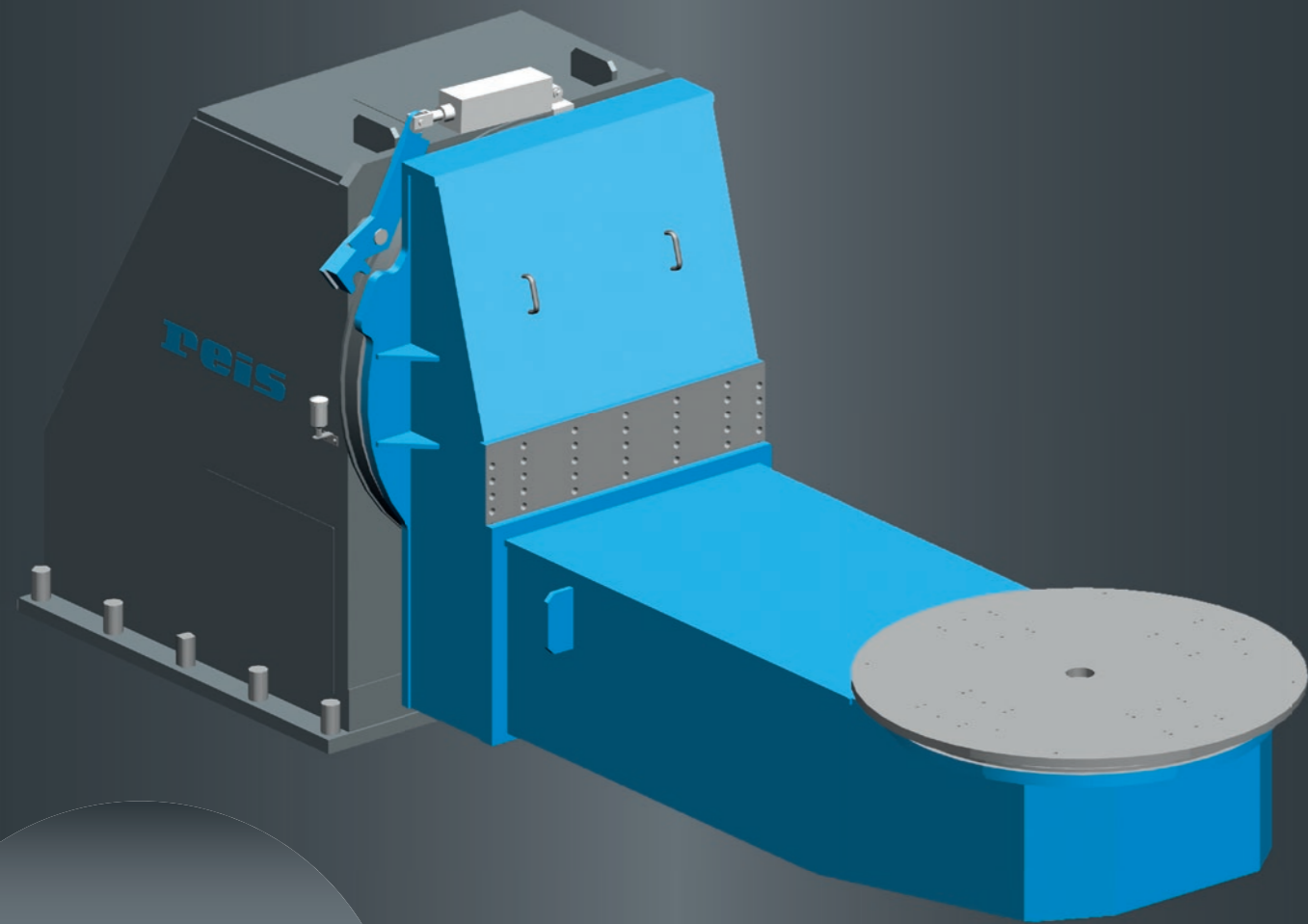

Freely programmable **1-axis rotary modules** for component positioning from 500 to 12,000 kg

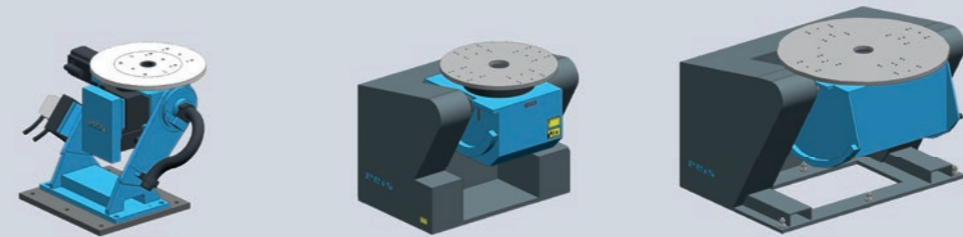

2-axis turn-tilt modules freely programmable for component positioning from 500 to 2,600 kg



2-axis rotary swivel modules freely programmable for component positioning from 500 to 5,000 kg

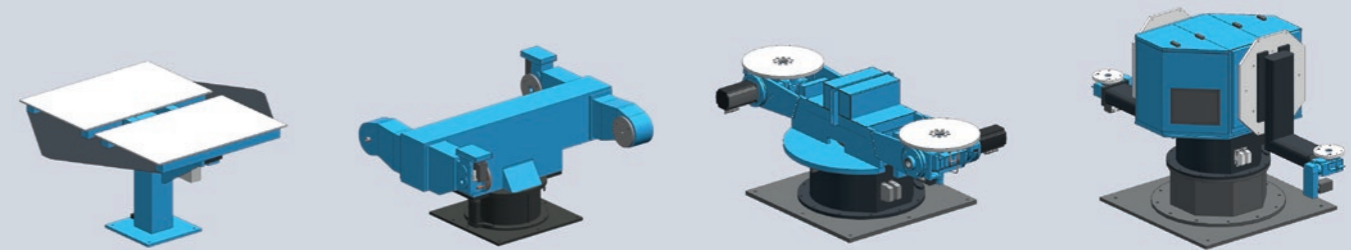

2 stations 180° rotary tables manual/electric with/without freely programmable additional axes for component positioning



SYSTEM CONCEPTS

Inexpensive standard systems offer an innovative solution for automation in the industry. The available standard peripheral modules are fully programmable and seamlessly integrated into the control software. This integration enables efficient and flexible handling of the workpieces so that they can be optimally positioned in relation to the robot. optimally positioned to the robot.

Thanks to this sophisticated technology, production processes can be optimized and the best results achieved in terms of efficiency and productivity. The possibility of free programming also ensures that the systems can be easily adapted to specific requirements, which significantly increases the versatility and application possibilities of the standard systems.

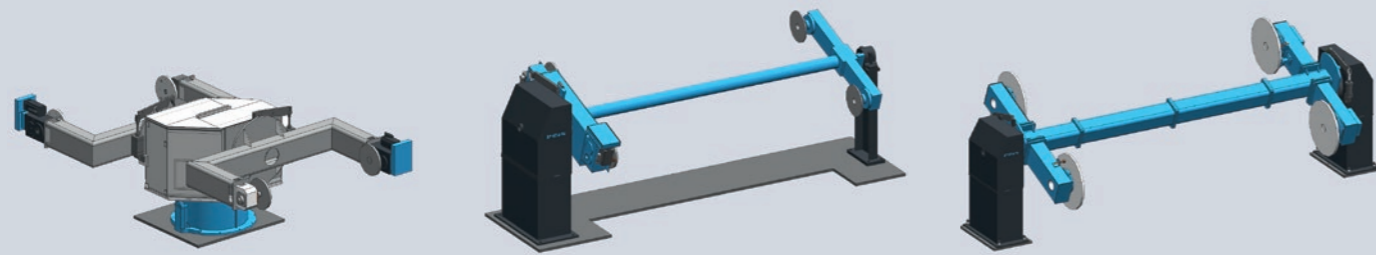

2 stations 180° electric rotary/tilt positioner with freely programmable additional axes for component positioning

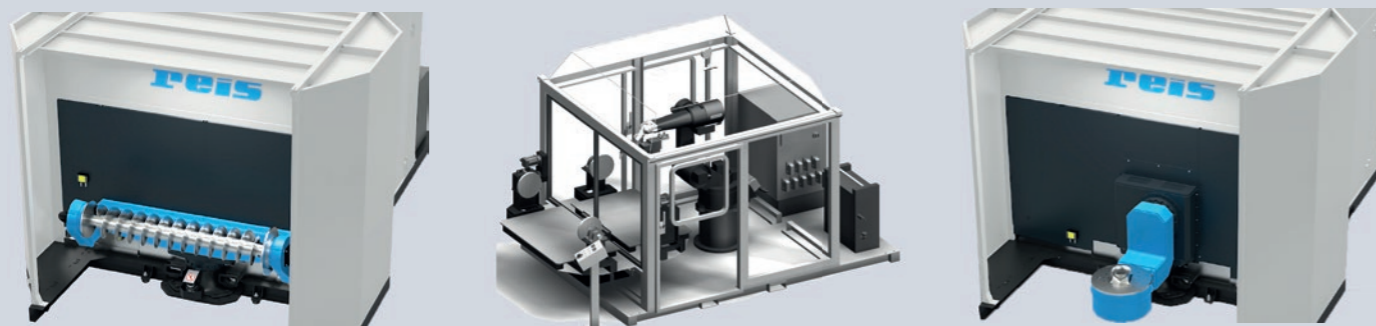

Cells based on standard components with complete protective device and transportable – plug and weld



C-stand with/without additional axes to enlarge the robot working area

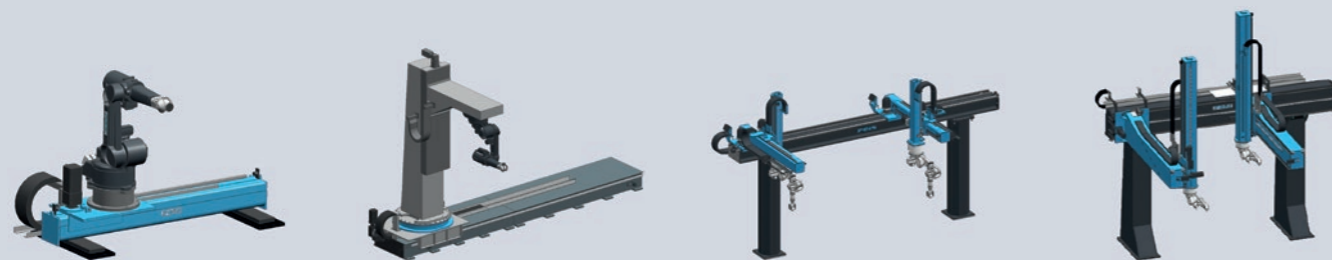

Floor traversing units or 1–3 axis gantry units as external additional axis to enlarge the robot working area

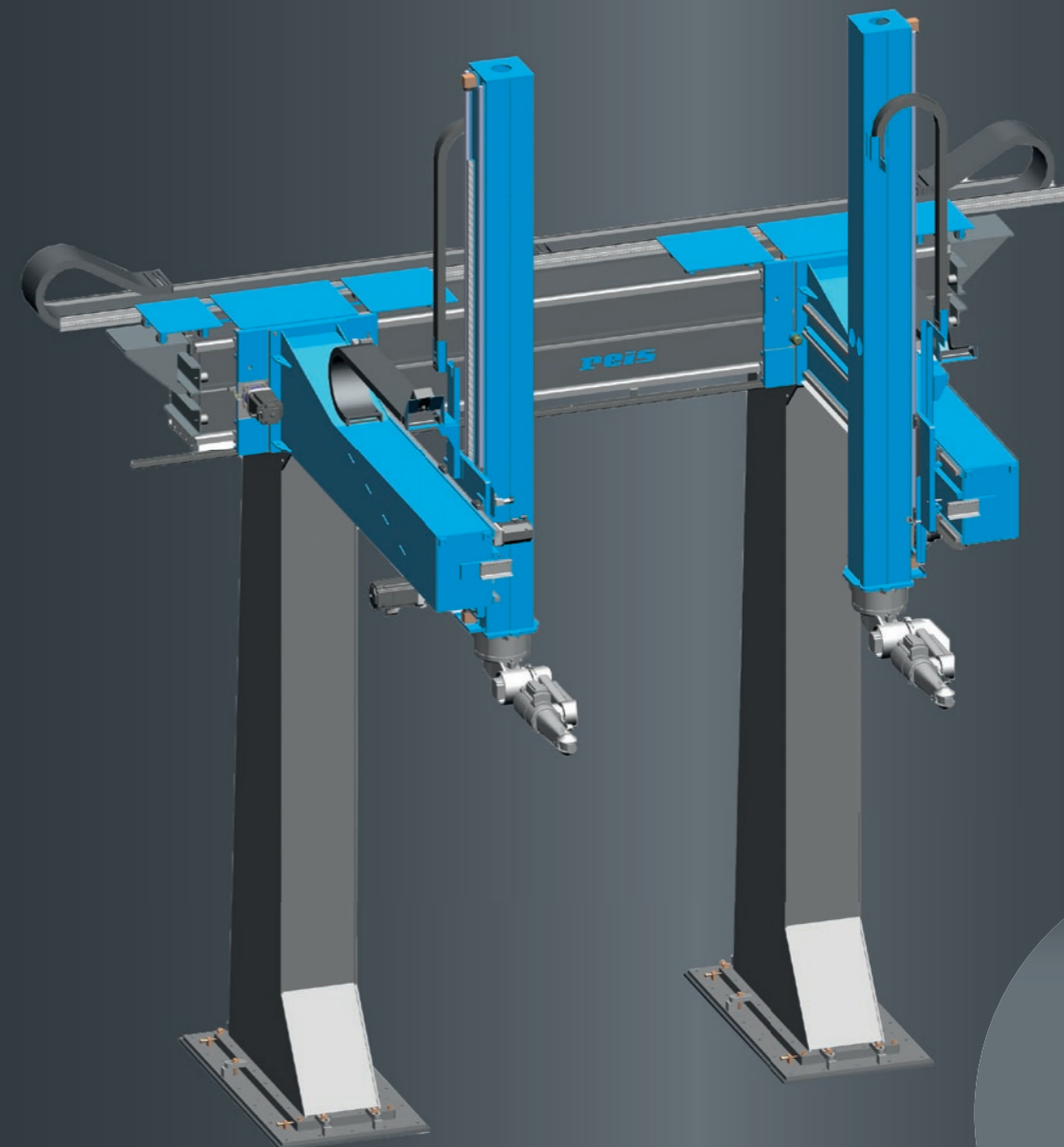

SYSTEM INSTALLATIONS ON REQUEST WITH MULTIPLE PROCESSES

Multi-process systems based on standardized system modules can map a wide variety of joining processes, but can also be combined with other technologies such as bonding, coating, hardening, marking or signing.

The system shown here as an example is mainly used for laser processing of large tools that are used in press shops. Punches and dies must be individually adjusted to the "µ" and incorporated in order to achieve high workpiece quality.

Laser cladding is programmed offline for surface build-up on new tools or repair welding on used tools. Tools can be coated with the laser and milled surfaces can be hardened. Laser beam hardening can be used to produce varying track widths of 5–80 mm as a robot track. A pyrometer is used to regulate the laser power in order to guarantee a constant line energy and thus ensure the specified hardness.

A 3D triangular laser scanner located on the laser optics can be used to scan the component surface in 3D and/or record the actual component position.

Processing optics with different powder nozzle types, coaxial round or multi-jet nozzles are available for defined processes. Narrow and wide welding paths can be produced with track width regulation. Various powder conveyors are used to mix the powders or feed carbides directly to the processing head.

The change of machining processes is fully automated, in individual cases the tool change can also be carried out manually and components weighing up to 20 tons are not uncommon. For this reason, the L-Shape door/roof design can be opened accordingly for crane operation.

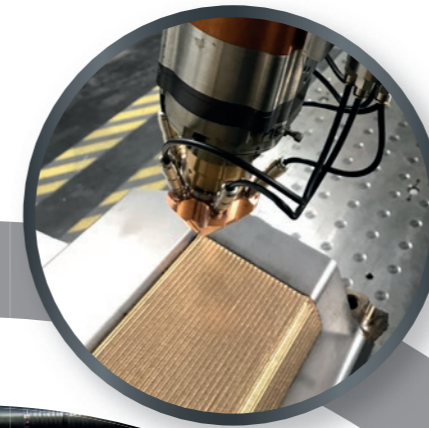

LASER CLADDING

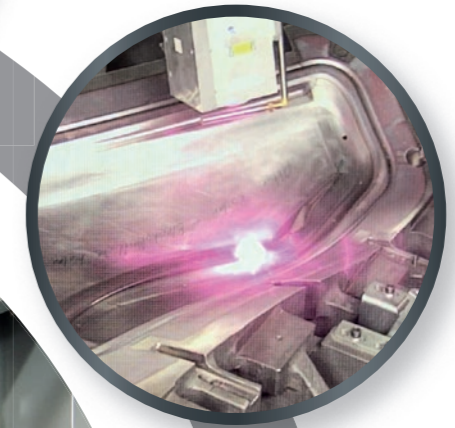

LASER HARDENING

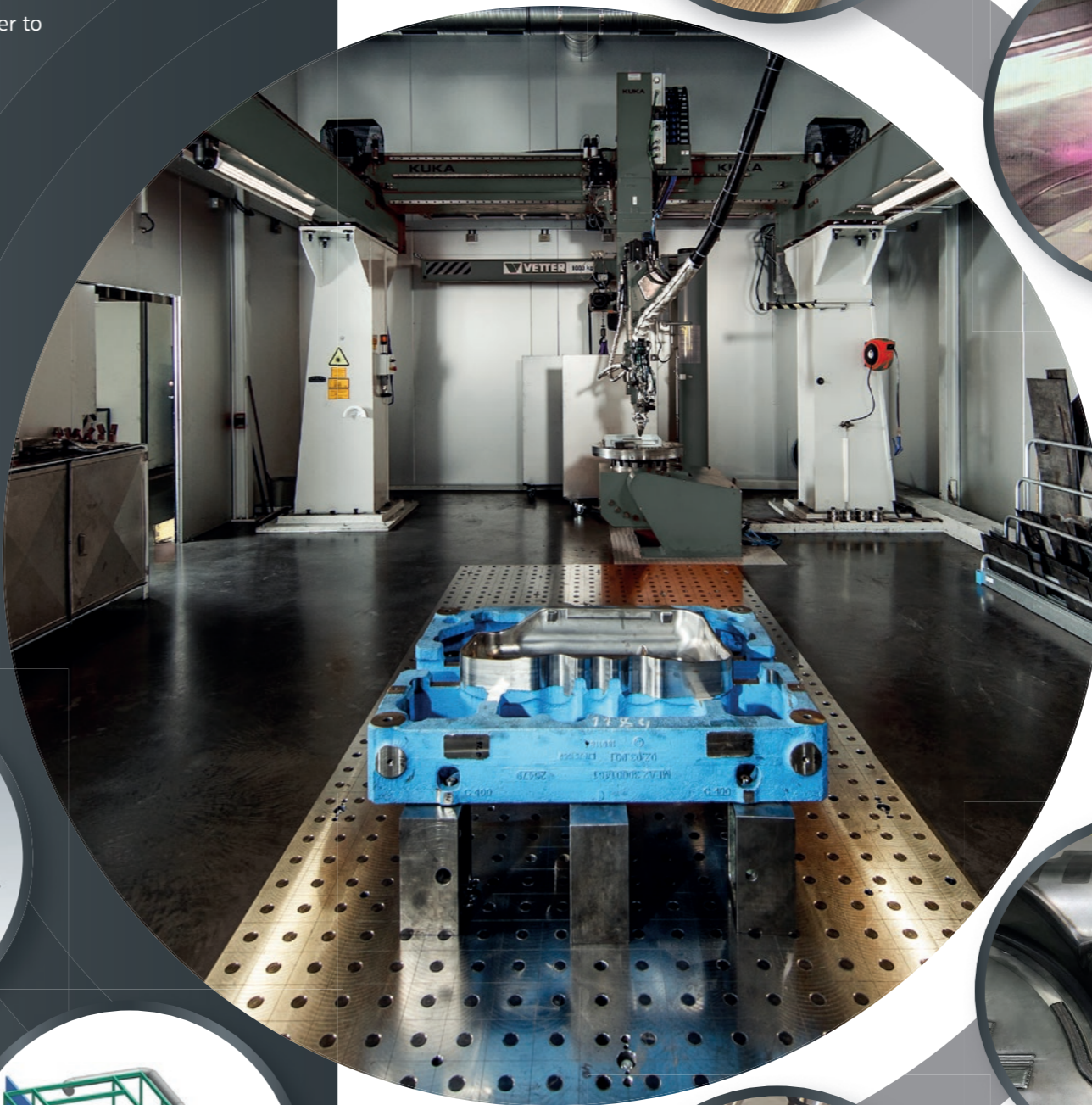

QA SYSTEM

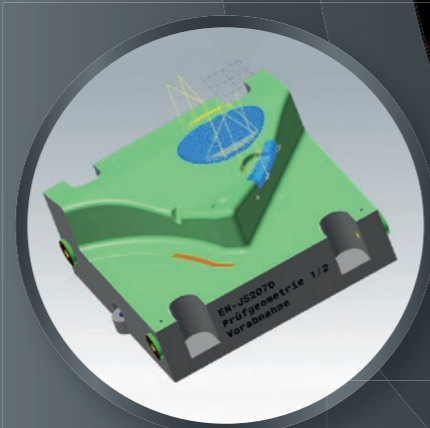

OFFLINE
PROGRAMMING



SIMULATION



PRODUCTS



TAPPING
SURFACES





For further information, please contact us at sales@reisrobotics.com

Specifications regarding the characteristics and usability of the products do not constitute a warranty of properties. They are intended to serve informative purposes only. Solely the respective contract of sale shall be binding in respect of the extent of our services and supplies. Some items of equipment depicted in the illustrations are optional and are not included in the standard scope of supply. Technical Data and illustrations are not binding for the delivery. Subject to change without prior notice.



Learn more about our company

Obernburg, Headquarters – Reis Robotics GmbH & Co. KG

Walter-Reis-Straße 1 · 63785 Obernburg / Germany · Phone +49 6022 503-0 · sales@reisrobotics.com

United States of America – Reis Robotics US Inc.

10501 Franklin Ave. STE 400 Franklin Park, IL 60131 · Phone +1 773 341-9468 · info.us@reisrobotics.com

Mexico – Reis Robotics S.A. de C.V

Av. Ricardo Margain 575 · Edificio C-PB · Parque Corporativo Santa Engracia · San Pedro Garza Garcia, Nuevo Leon / Mexico · Phone +52 (81) 8000-7347 (8000-REIS) · info@reisrobotics.com.mx

Follow us on:



www.reisrobotics.com

A company of **ARETÈ COCCHI TECHNOLOGY**

