

# LINEAR ROBOT **RL80**

## FOR ENHANCED QUALITY AND PRODUCTIVITY IN LARGE-SCALE WORKSPACES

In its maximum configuration, the **RL80 linear robot** has three cartesian axes and three rotary axes, which are fully synchronized and interpolated servo axes controlled by the robot controller.

The experience gained from a large number of installed handling applications and our expertise as one of the leading providers of intelligent automation solutions for more than five decades have been incorporated into the development of the new **RL80**.

### YOUR BENEFITS

- combined with the very low interference contours of the robot kinematics, this is ideal for interlinking work sequences for loading and unloading, but also for palletizing or transferring
- modular design with workspaces from 1 m<sup>3</sup> to 255 m<sup>3</sup> make the linear robot a safe investment for your automation system
- state-of-the-art servo drive technologies are used to achieve the best possible dynamics, performance and reliability

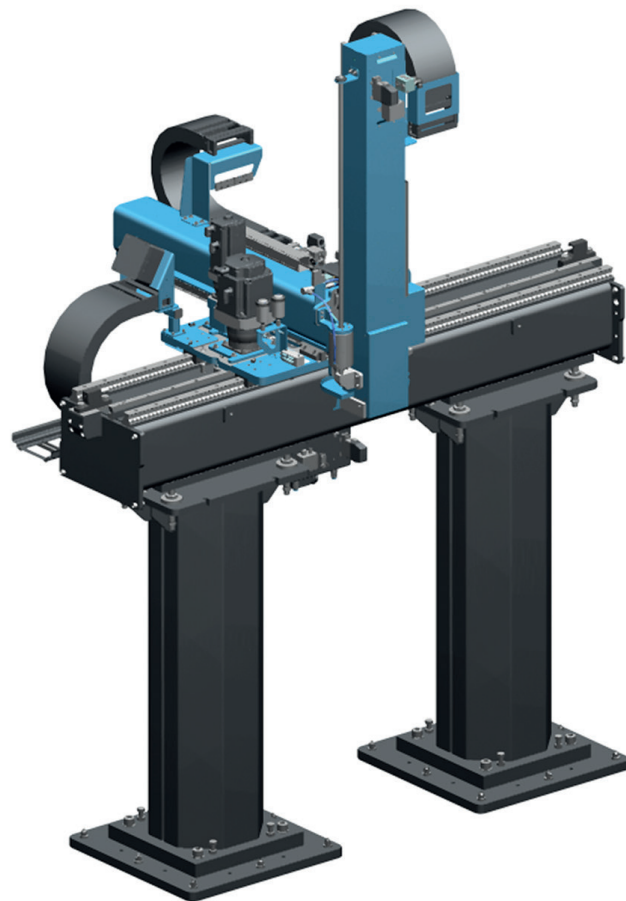

### SCOPE OF SUPPLY INCLUDING

- **RL80** with flexible stroke and staggered operating height  
Basic stroke:  
A1 = 2,000 mm,  
A2 = 500 mm,  
A3 = 1,000 mm

### OPTIONS

- Wrist axle modules
- Incremental stroke lengths A1 – A3
- Incremental height adjustment of the support columns
- Additional brake A3
- Central lubrication system
- Energy supply
- Adapted to customer specifications
- Extra seals for guiding systems
- Drip protection



# LINEAR ROBOT RL80

## Technical data

Nominal payload capacity	kg	80
Payload range (depending on stroke A3)	kg	55 to 127
Repeat positioning accuracy	mm	± 0.1
Number of axes		3
Work envelope	m <sup>3</sup>	1 to 255
Medium power consumption	kVA	4.8
Connected load	kVA	7.5
Weight of basic stroke A1 – A3 (without support columns, without load)	kg	approx 1,200

## Velocities

A1	m/s	2.6
A2	m/s	2
A3	m/s	3

## Strokes

		A1	A2	A3
Basic stroke	mm	2,000	500	1,000
Max. stroke	mm	45,000	2,000	2,500
Extension steps	mm	1,000	250	250
Extra weight for each upgrade	kg	320	24	12

## Support column

Basic size (ø)	mm	450
Basic height	mm	1,750
Maximum height	mm	3,000
Height of extension steps	mm	250
Support column spacing (max.)	mm	5,000
Support arm projection (max.)	mm	1,250

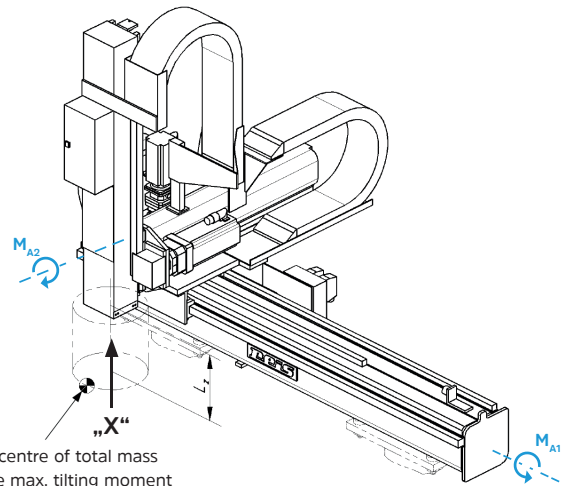

## Table Maximum load A3

Stroke lengths A3 [mm]	Load (max.)	
1.000	kg	127
1.250	kg	115
1.500	kg	103
1.750	kg	91
2.000	kg	79
2.250	kg	67
2.500	kg	55

## Max. lever arm with max. load

Lz	mm	200
----	----	-----

For further information please contact us under: [sales@reisrobotics.com](mailto:sales@reisrobotics.com)

**Reis Robotics GmbH & Co. KG**  
 Walter-Reis-Straße 1  
 63785 Obernburg / Germany  
 Phone +49 6022 503-0

Statements on quality and usability of the products are no warranty of properties, but are for information only. The relevant object of the contract is decisive for the scope of our supply and services. Some illustrations may contain optional equipment that is not included in the standard scope of supply.

Technical data and illustrations are not binding for deliveries. Subject to changes.

# LINEAR ROBOT RL80

## ADDITIONAL LOAD

### Additional load on axis A1 and axis A2

Type	stroke lengths A2 / D	Additional load moving along on A1		Additional load moving along on A2	
		max. mass	max. admissible moment around center of support arm A1, generated by $L_{A1}$ and $L_{A2}$	max. mass	max. admissible moment around center of support arm A2
	[mm]	$L_{A1}$ [kg]	$M_{A1}$ [Nm]	$L_{A2}$ [kg]	$M_{A2}$ [Nm]
RL80	500	195 - $L_{A2}$	2,496	165	+/- 248
	750	170 - $L_{A2}$	2,176	140	+/- 210
	1,000	145 - $L_{A2}$	1,856	115	+/- 173
	1,250	120 - $L_{A2}$	1,536	90	+/- 135
	1,500	95 - $L_{A2}$	1,216	65	+/- 98
	1,750	70 - $L_{A2}$	896	40	+/- 60
	2,000	45 - $L_{A2}$	576	15	+/- 23

D = Verlängerung Ausleger

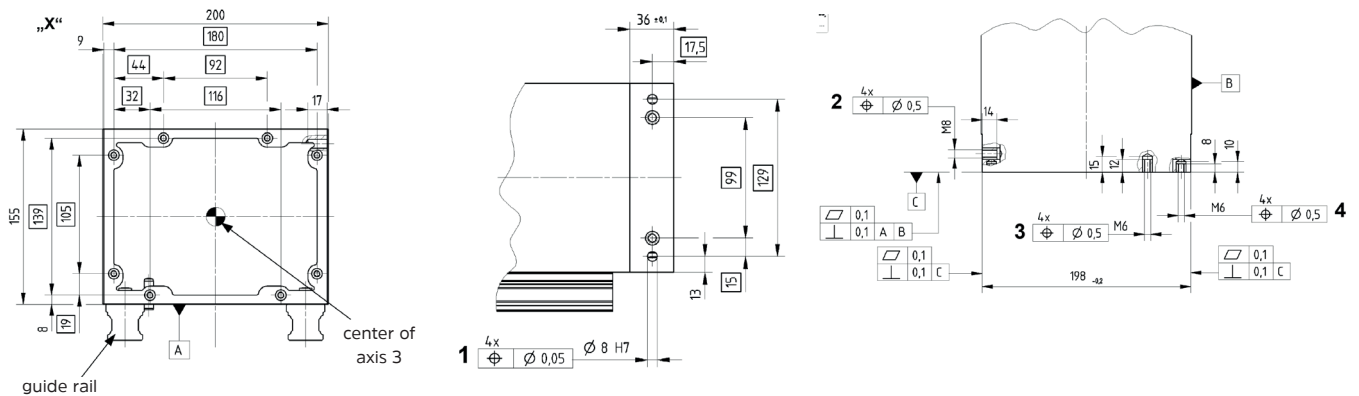

For further information please contact us under: [sales@reisrobotics.com](mailto:sales@reisrobotics.com)

**Reis Robotics GmbH & Co. KG**  
 Walter-Reis-Straße 1  
 63785 Obernburg / Germany  
 Phone +49 6022 503-0

Statements on quality and usability of the products are no warranty of properties, but are for information only. The relevant object of the contract is decisive for the scope of our supply and services. Some illustrations may contain optional equipment that is not included in the standard scope of supply.

Technical data and illustrations are not binding for deliveries. Subject to changes.

# LINEAR ROBOT RL80

## WORK ENVELOPE

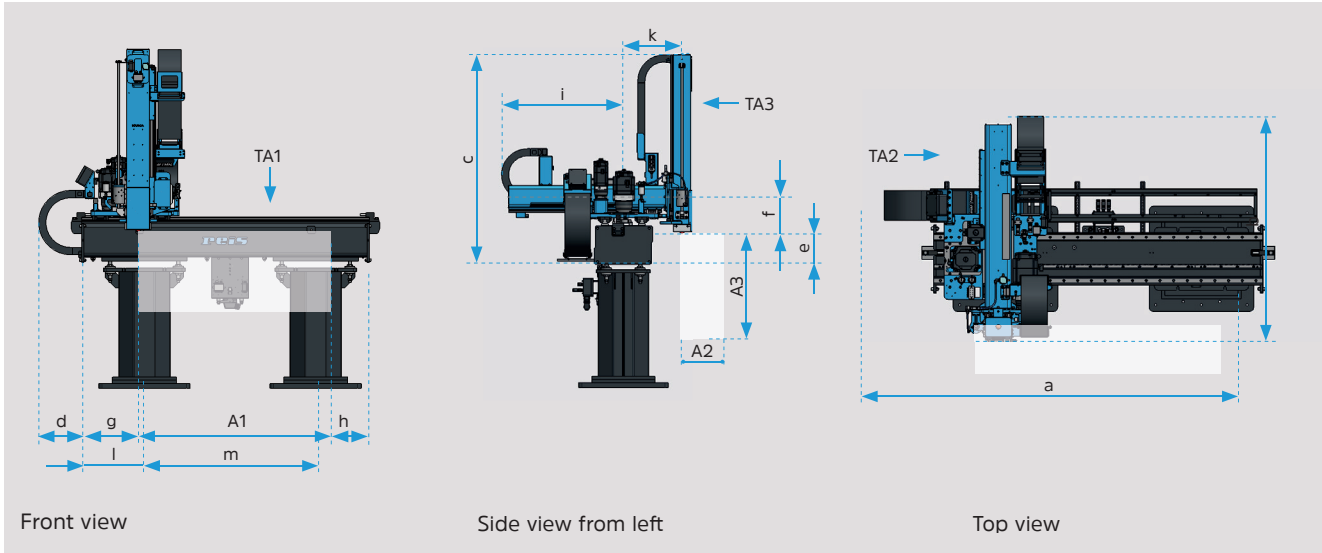

### Legend

- A1** Stroke axis 1
- A2** Stroke axis 2
- A3** Stroke axis 3

- TAx** Support arm Axis x
- WS** Tool interface A3
- UK** Bottom edge
- OK** Upper edge

### Space requirement/footprint

<b>a</b>	Overall length	mm	$A1 + 1,255$	<b>h</b>	End TA1 to WS	mm	385
<b>b</b>	Total width	mm	$A2 + 1,210$	<b>i</b>	Protrusion TA2 Center A1	mm	$A2 + 580$
<b>c</b>	Total height (without stand)	mm	$A3 + 825$	<b>k</b>	Center TA1 to WS	mm	530
<b>d</b>	Overhang E-chain	mm	375	<b>l</b>	Max. ledge projection TA1	mm	1,250
<b>e</b>	Lower TA1 to WS	mm	245	<b>m</b>	Max. distance between uprights	mm	6,500
<b>f</b>	Center TA2 to WS	mm	315				
<b>g</b>	Start TA1 to WS	mm	505				

For further information please contact us under: [sales@reisrobotics.com](mailto:sales@reisrobotics.com)

**Reis Robotics GmbH & Co. KG**  
 Walter-Reis-Straße 1  
 63785 Obernburg / Germany  
 Phone +49 6022 503-0

Statements on quality and usability of the products are no warranty of properties, but are for information only. The relevant object of the contract is decisive for the scope of our supply and services. Some illustrations may contain optional equipment that is not included in the standard scope of supply.

Technical data and illustrations are not binding for deliveries. Subject to changes.

